

T-i^x User Guide

For all T-i^x Models



T-i^x

T-i^x user guide for all T-i^x models



	Page
Important	2
Introduction	3
Using the T-i ^x effectively.....	3
Safety information- Using the T-i ^x safely	3
Contents	4
Installation	5
Ports	5
Display and buttons	6
 Counting	
What can be counted with T-i ^x	7
Counting tasks.....	8
Getting started	9
Switch on, home page, using the keypad, reference numbers, Z balance, banks	
Bills.....	11
Loose, strapped, clipped, sleeved	
Coins	13
Tellercup, full bags/rolls, part filled bags/rolls	
Other Media	15
Coupons / vouchers, tokens, key entered media	
Ending a count	16
Ending, reviewing & amending a count	
 Multi Till	
Tasks	17
View Tills	18
Amend.....	18
View Grand Totals.....	19
Print / Clear / Send	19
 Settings	
Unit Settings.....	20
Date & time, language, sound, display settings, port settings	
Set up Wizard	22
Diagnostics	23
Weighing Scale.....	24

Important

This equipment has been tested and found to comply with the limits for a Class B digital device, pursuant to part 15 of the FCC Rules. These limits are designed to provide reasonable protection against harmful interference in a residential installation. This equipment generates, uses and can radiate radio frequency energy and, if not installed and used in accordance with the instructions, may cause harmful interference to radio communications. However, there is no guarantee that interference will not occur in a particular installation. If this equipment does cause harmful interference to radio or television reception, which can be determined by turning the equipment off and on, the user is encouraged to try to correct the interference by one or more of the following measures:

Reorientate or relocate the receiving antenna.

Increase the separation between the equipment and receiver.

Connect the equipment into an outlet on a circuit different from that to which the receiver is connected.

Consult the dealer or an experienced radio/TV technician for help.

Modifications not expressly approved by the manufacturer could void the user's authority to operate the equipment under FCC rules.

For Users in Canada

This apparatus complies with 'class B' limits for radio interference as specified in the Canadian department of communications radio interference regulations

Pour L'utilisateurs Canadiens

Cet appareil numérique ne dépasse pas les limites de catégorie A pour les émissions de bruit radio émanant d'appareils numériques.

Tel que prévu dans les règlements sur l'interférence radio du département Canadien des communications.

Introduction

The Tellermate T-i^x range is the leading cash management solution for your business enabling you to quickly and efficiently count and manage your cash.

Stand-alone or connected directly to business reporting systems, T-i^x helps to increase the efficiency, security and accuracy of a wide range of cash management tasks:

- T-i^x counts all money formats such as those contained in a typical cash drawer:
- Bills (loose, strapped, clipped and sleeved bills)
- Coins (loose, bags, rolls)
- Non-cash items (Checks, credit card values, etc.)

T-i^x comes with optional connections to printer and PC systems. This document includes instructions on how to get started with your T-i^x and on how to configure the model to suit your preferences. (Please be aware that since there is a range of T-i^x models, not all features illustrated in this document may be present in the model that you purchased).

Caring for T-i^x:

Using T-i^x effectively

1. Use T-i^x on a stable, flat surface, free from vibrations and drafts* (air conditioning, fans, etc).
2. When counting bills, raise the coin tray – when counting coins, lower the coin tray.
3. When counting loose coins, use the Tellercups supplied by Tellermate
4. Place items on the unit carefully; do not throw or drop them.
5. Check the count mode carefully, eg. do not count coin rolls in the Tellercup mode.
6. Sort money before counting; mixed denominations cannot be counted.
7. Turn the unit OFF and carefully unplug all cables before carrying it in an upright position – use the finger grips on the underside.
8. Do not leave objects on the money platform when T-i^x is not in use. Not even a Tellercup.
9. This unit cannot identify counterfeit money.
10. Charge the battery (if supplied) for 4 hours before first use; replace it when advised on-screen.

How to use T-i^x in a safe manner

- Caution – Lithium battery. Risk of explosion if battery is replaced by an incorrect type.
- Keep T-i^x clean with a dry cloth only. Do not use sprays, wet / damp products or immerse in liquid.
- If liquid is spilled on T-i^x, as soon as it is safe, turn off the power. Contact your supplier for assistance.
- Do not subject T-i^x to impacts or shocks by hitting or dropping it.
- If the casing of the power adaptor is cracked or broken. disconnect power and contact your supplier for assistance.
- Do not place items weighing over 2kg/4.40lbs on T-i^x.
- Always use and store T-i^x on a flat and stable surface - injury may be caused to the user if it falls.
- The power socket must be near T-i^x and easily accessible. Do not misuse or apply force to the cables.
- Do not disassemble T-i^x.
- Do not use pens or tools to operate the buttons.
- Dispose of T-i^x and batteries in accordance with local regulations.

Failure to follow these instructions may cause permanent damage to the T-i^x unit and void the warranty.

What you get



T-iX

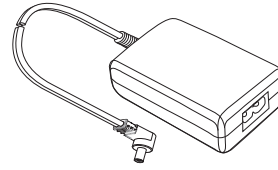

Universal Power Supply
& power cord
with interchangeable adaptors

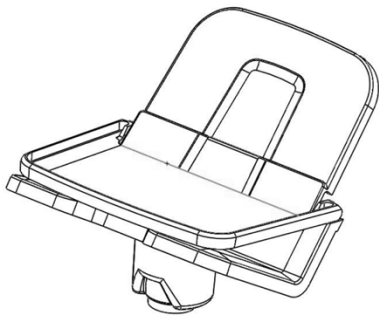

Money Platform

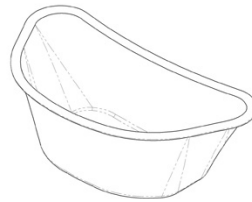

TellerCup Z-160



Quick Start Guide

Optional Extras

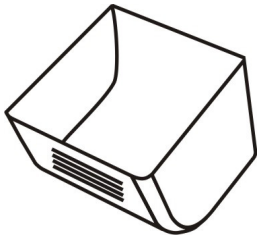

TellerCup

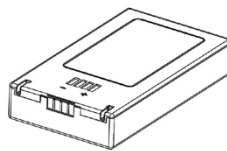

Battery

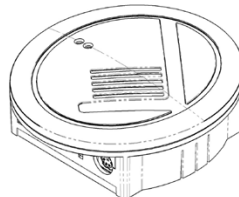

TellerComK

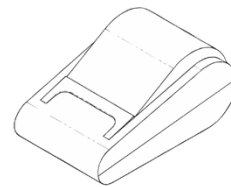

Printer

If you require any further information about the optional items please contact your nearest Tellermate dealer.

Installation

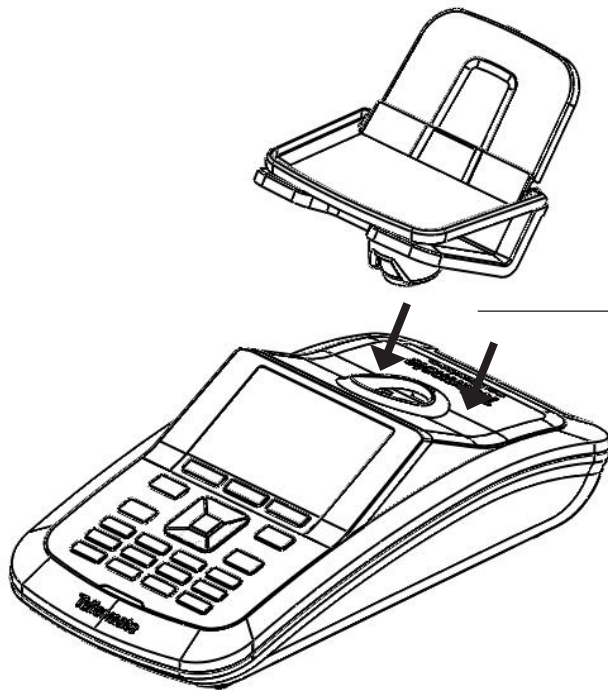

To fit, lower the Money Platform down until the magnetic connector slots into position. To release, twist and lift.

Rear Ports

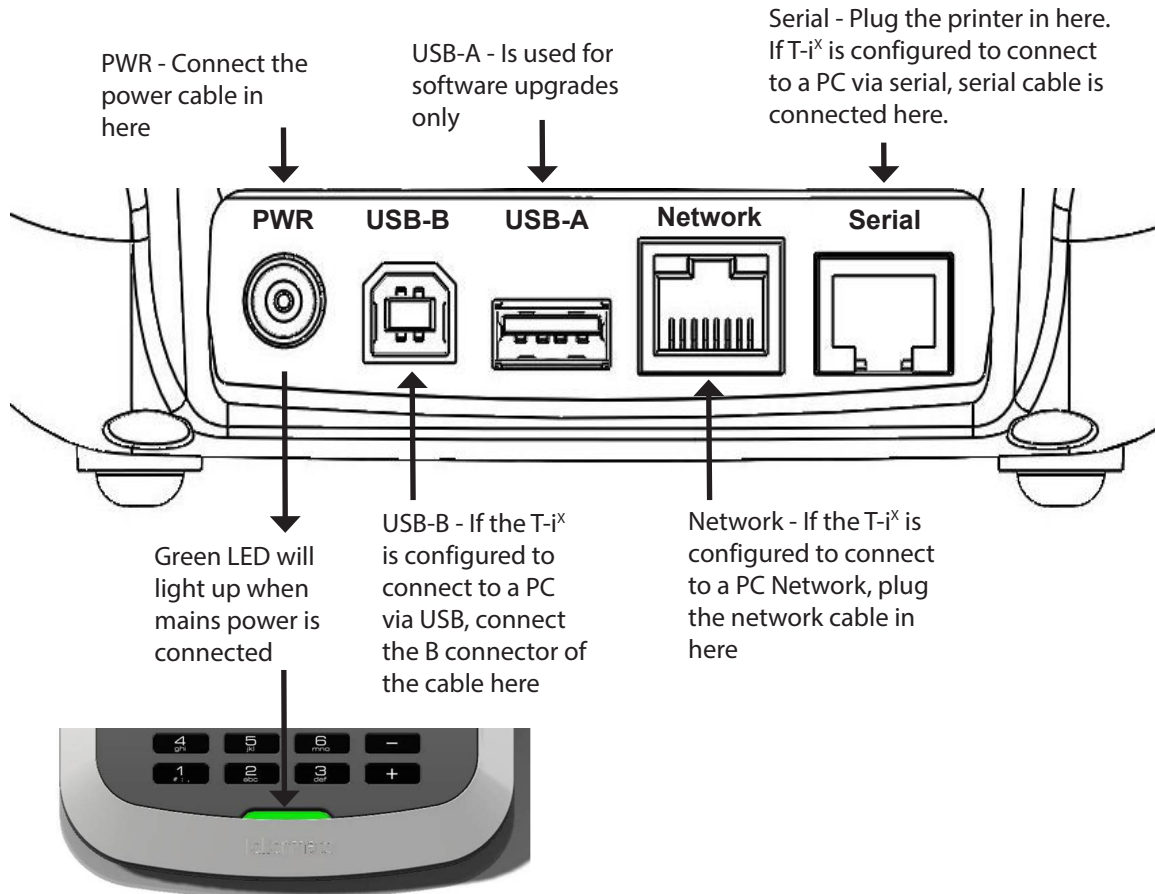

Display and Buttons









What can be counted with T-i^x





Money Counting Modes

T-i^x has many different modes for counting money. A mode is a term used by TellerMate to describe the different ways in which money is packaged. Modes will differ according to T-i^x model.

It is extremely important when counting money that the T-i^x is set to the correct mode, to avoid miscounts.

Mode	Description
Loose bills 	For counting loose bills of the selected denomination. Loose bills are counted by placing 15-20 bills on the money platform at any one time. This stacking process is repeated until all the bills have been counted.
Straped bills 	For counting Straps of straped bills of the selected denomination. Bills have to be strapped together in a fixed quantity. A typical strap quantity is 50 or 100 bills. Each strap must be placed on the money platform one on top of another.
Clipped bills 	For counting bills of the selected denomination that are clipped together in a fixed quantity. A typical clip quantity is 10 or 20 bills.
Sleeved bills 	For counting bills of the selected denomination that are packaged in a sleeve in a fixed quantity. A typical sleeve quantity is 50 or 100 bills.
Bagged/ Rolled coin 	For counting bagged/rolled coins of a selected denomination. Bags/Rolls can be counted even if only part full.
TellerCup 	For counting loose coin of a selected denomination in a TellerCup.
Full Bag/roll 	For counting full bags/rolls of any denomination.

Counting - Tasks

From the Home screen press  to select a task then press  to confirm.

*Counting tasks differ by T-i^x model, your T-i^x may have some but not all of the tasks described below.

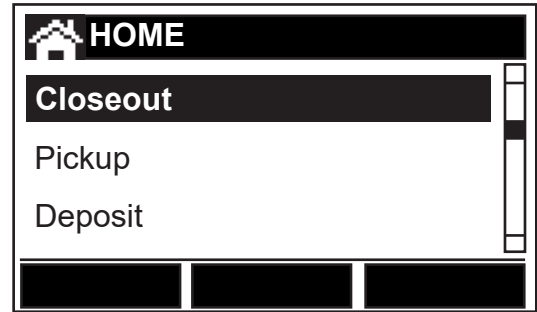

Task Type	Description
Closeout	At the end of a shift or the working day, user counts the contents of a cash drawer, or other organised collection of money. This identifies the overall cash total and allows preparation of a pre-determined amount of cash as a change bank. Alternatively, the user completes the same function but leaves no bank.
Deposit	User prepares money for deposit at a bank or collection by a “cash-in-transit” organisation. Includes the preparation of full rolls of coin or straps of bills and is likely to concentrate on the counting of prepared straps and bags.
Safe Check	User counts the contents of a safe that might also have a nominated amount of money (bank) that is retained to provide change to drawers.
Register audit	For added security, user may conduct a spot audit on a given drawer. This gives greater visibility of drawer contents against an expected figure to prevent unauthorised removal of cash and is also useful to quickly check customer claims of being short changed. Register audit counts do not get added into the grand total.
Pickup	User counts the high-value bills and vouchers that are removed from the drawer to prevent excessive values of cash being held “on the shop floor” throughout the working day.
Bank Check	User checks the contents of drawers that have pre-prepared start banks prior to issuing to a cashier.
Bulk Bills	User validates the contents of “bricks” or straps of bills by comparing a weight displayed on the unit with a table of permissible weights for the selected denomination.
Payment Check	User checks the value of a number of bills (loose, strapped, clipped or sleeved) and rolls of coins before accepting them from, or issuing them to, a customer.

Counting - Getting Started

Starting



To switch on-

Press the  key.



Home Page

The T-i^x software will come with pre-programmed counting tasks to help process money.



Use the  keys to select a count task and confirm by pressing .



Using the keypad (only on selected models)

The keypad allows one to enter reference numbers and the value of "other media" items such as checks and credit cards. It can also be used to directly enter the amount of any denomination, rather than counting it on T-i^x.

Keying in a value



In count mode select the denomination using the  keys, enter the value of the denomination using the keypad then press the  key to confirm the amount.

If a mistake has been made when entering a denomination, select the denomination and press the  key to clear the entry and start again.



Counting - Getting Started

Reference Numbers

T-i^x has the capability to input reference numbers for Registers, Cashiers, Operator and Store*. To enter a reference number simply use  to highlight the reference, (Register is highlighted in this illustration) then press  to nudge the reference number between 0-99.

For T-i^x models with a numeric keypad the user can key in the number via the keypad and confirm by pressing .

* Only available with certain models.

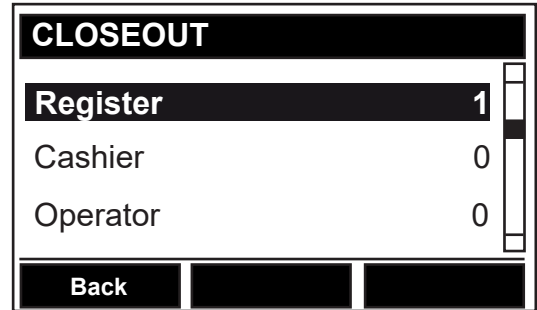

Z Balance**

** only available on models with a keypad

In certain models the user may be required to enter a Z Balance (Also known as Expected Take, Zread, Xread). This is the expected take for the day and the till contents will be counted and balanced against this figure. To enter a Z balance simply key in the value using the keypad and press  to confirm.

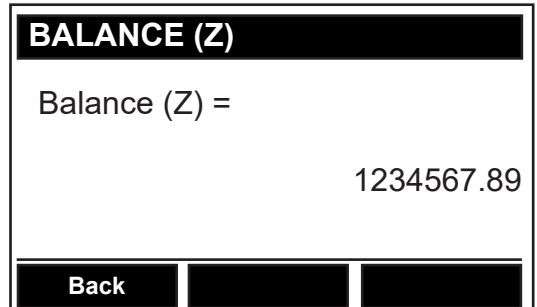

Selecting a Bank Value*

T-i^x models may be programmed with 4 preset bank values.

A bank value can be chosen at the beginning of a count before anything has been added by pressing the right hand , named "Bank" in the illustration. Repeatedly press this button to scroll through the 4 preset values and no bank. Once a bank value has been chosen, begin the count and the bank value will be deducted from the total at the end of the count.

* Only available with certain models.

** Only available on models with a keypad.

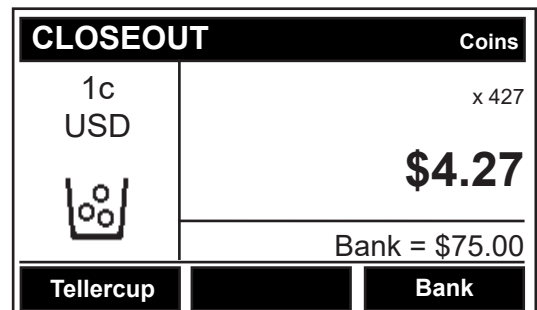

Counting - Bills

Counting Loose Bills

Count one denomination at a time.

Use the  key to select the denomination. Stack the bills against the short side of the Money Platform with the platform up as per diagram.

Stack in batches of 15-20 bills at a time without removing them. T-i^x will beep to confirm the money has been placed on the Money Platform.

Leave the first stack on the Money Platform and add the next stack of the same denomination. When finished with a denomination remove all of the bills together. T-i^x will beep to confirm the money has been counted and added to the total.

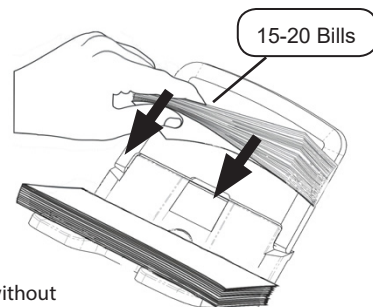



CLOSEOUT		Bills
\$5 USD		x 15
		\$75.00
#1 Total =		\$16.09
Loose		

Counting Strapped Bills

Straped bills (e.g. 50 or 100 bills) of the same denomination can be counted without removing the band.

Use the  key to select the denomination.

Press the left hand  key to select Strap mode. Put the first Strap on the money platform. When the value is displayed, more strapped bills of the same denomination may be added.

If REMOVE BAND appears, remove all the bills from the money platform, press the left hand  key to select "loose" count mode and count the last Strap in batches of 15-20.

CLOSEOUT		Bills
\$5 USD		x 100
		\$500.00
#1 Total =		\$92.09
Strap		

Counting clipped bills*

*Clips must be calibrated prior to use

Use the  key to select the denomination.

Press the left hand  key to select clip mode. Put the first clipped Strap on the Money Platform. When the value is displayed, more clipped bills may be added.

If REMOVE CLIP appears, remove all the bills from the Money Platform, press the  key to select loose count mode and count in batches of 15-20.

CLOSEOUT		Bills
\$5 USD		x 10
		\$50.00
#1 Total =		\$592.09
Clip		

Counting - Bills

Counting Sleeved Bills

Use the  key to select the denomination.

Press the left hand  key to select sleeve mode.

Place the first sleeved Strap on the Money Platform.
When the value is displayed, more sleeved bills may be added.

If REMOVE SLEEVE appears, remove all the bills from the Money Platform, press the left hand  key to select loose count mode and count in batches of 15-20.



CLOSEOUT		Bills
\$5 USD		x 100
		\$500.00
#1 Total =		\$642.09
Sleeve		

Counting - Coins

Counting Full Rolls

T-i^x is set up to count full coin rolls of any denomination.

The next three sections show how to count full rolls.



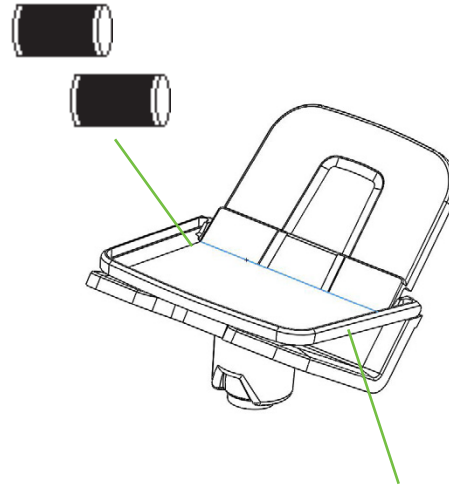

- Use the  key to select Full Roll.
- Place the full roll on the Money Platform. (T-i^x will automatically recognise the denomination)
- If there are more full rolls place them on the Platform one by one.
- T-i^x will hold about 5-6 full rolls on the platform.
- If "SUSPECT ROLL" is displayed, scroll to the correct denomination  using the button. The total value of the roll will be displayed.





When counting coins in rolls or a Tellercup it is advised that the tray is placed down as shown in picture

Review Full Roll Table

This mode allows one to view, clear or manually enter the Full Rolls that have been counted.

- Use the  key to select Full Roll.
- Press the left hand  key to access the review table.
- Select the denomination by using the  key.
- To clear a denomination press the  key.

To manually enter a denomination press the right hand  labelled + or center  key labelled -

to increase / decrease full roll quantities by denomination by increments of x 1 full roll. Alternatively, to input or remove larger quantities of rolled coin, key in the number of rolls then press the  key labelled - or +.

Press the left hand  to return to the Full Roll count screen.

CLOSEOUT		Full Roll
Full Roll USD 	++Added++	
#1 Total =		\$41.09
Review		



REVIEW SCREEN FOR		Full Roll
1c x (2)		1.00
5c x (2)		4.00
10c x (6)		30.00
Back	-	+

Counting - Coins

Counting Rolls (or partial rolls)



Roll mode allows the user to count the contents of a roll (full / part full) of a pre-selected denomination.



- Use the  key to select the denomination.
- Press the left hand  key to select Roll mode (see pg 6 for counting modes).
- Put the roll on the Money Platform and T-i^x will display the value of its contents.

CLOSEOUT		Coins
1c USD	++Added++	
		
#1 Total =		\$42.09
Roll		

Counting with a TellerCup



Cup mode allows the user to count loose coins. Each denomination must to be counted separately.

- Use the  key to select the denomination.
- Press the left hand  key to select TellerCup mode (see pg 6 for counting modes).
- Place the TellerCup on the Money Platform; T-i^x will display the value of its contents.

CLOSEOUT		Coins
5c USD	x 117	
	\$5.85	
#1 Total =		\$42.09
TellerCup		



To make up full rolls of coin, place the empty TellerCup on the Money Platform and add coins until the required value is displayed.

When "AutoScroll" is activated T-i^x will scroll automatically to the next denomination, in sequence from the lowest to the highest value.



Coin denominations must always be separated before counting.

Do not count rolls of coin in the TellerCups; place them directly onto the Money Platform.

Do not stack multiple rolls of coin on the denomination screen. Roll stacking is only available for Full Roll.

Counting - Other Media

Counting Coupons/Vouchers

Use the  keys to select coupons (see top right of display).

Use the  keys to scroll through the enabled coupons. Coupons and vouchers can be counted by stacking on the money platform in the same way as bills. Alternatively, the values can be keyed in using the numeric keypad.**

** only available with certain models

For coupon set up see page 22

CLOSEOUT		Coupons
Gift Cert USD		x 15
		\$75.00
	#1 Total =	\$16.09
Loose		

Counting Tokens

Use the  keys to select tokens (see top right of display).

Use the  keys to scroll through the enabled tokens. Tokens can be counted in the same way as coins or alternatively the values can be keyed in using the numeric keypad.**

** only available with certain models

For token set up see page 22



CLOSEOUT		Tokens
Token1 USD		
		++Added++
	#1 Total =	\$42.09
Roll		

Other Media*

*Only available in models with a keypad

This function caters for positive or negative monetary values that can not be weighed i.e. checks, electronic (card) payments, refunds and petty cash.

Use the  keys to select Other Media (see top right of display).

Use the left hand  key to scroll through the enabled Other Media items. Key in the value for each individual item and add it to the total by pressing the  or  to enter positive or negative values.

For other media set up see page 22

CLOSEOUT		Other Media
1234.00	#1	1.00
	#2	4.00
	#3	3.00
	#1 Total =	\$47.09
Check		

Counting - Ending a Count

Ending a Count

When all items have been counted press the **END** key. This ends the current count and displays the Count Summary screen (see illustration). To view a count summary of another currency that has been counted simply press the middle **I** key for currency.

COUNT SUMMARY		
1c	(437)	\$4.37
5c	(117)	\$5.85
10c	(89)	\$8.90
Back	Currency	

Reviewing & Amending the Count

Scroll up and down using the **↑/↓** key to review the count. If the summary is satisfactory press **END** to move on to COUNT REVIEW (See below).

If an error has been made or an amendment is needed, scroll to the item that needs to be amended and press **OK** to confirm. A screen will then display the item to be edited.

COUNT REVIEW	
Total	\$1234.56
Reference Numbers	
Bank	\$50.00
Back	



COUNT REVIEW	
Balance	\$1240.00
Under by	\$-5.44
Back	

End of Count Options

Pressing **END** on the Count Review screen above will then display the End of Count Options.

END OF COUNT OPTIONS	
Next Register	
Print Register	
Send Register	
Back	



END OF COUNT OPTIONS	
Clear Register	
END/Home	
Back	

Summary of End of Count options:*

Next Register - Starts a new register of the current counting task. When using a multi till unit, current register data will be saved to memory.

Print Register - Prints count results from current register.

Send Register - Sends current data to PC.

Clear Register - Clears the current data and returns to the Home Page.

End/Home - Ends current count and returns to the Home Page.

*Options are model specific, not all options may be available in your model.

Counting - Multi Till

Tasks and Multiple Transactions

For models T-i^x 3550 & T-i^x 4550

T-i^x multi-till software comes with pre-programmed tasks to help process money. Furthermore T-i^x can process multiple transactions from many cashiers and registers. When a register number is entered T-i^x searches its internal records to see if this drawer has previously been used. Any new transactions will be added into the GRAND TOTAL with those that have already been processed.

T-i^x multi-till allows the user to count, store and consolidate up to 150 registers.

Tasks

To select a task press the  key. To confirm and start the task press the  key.

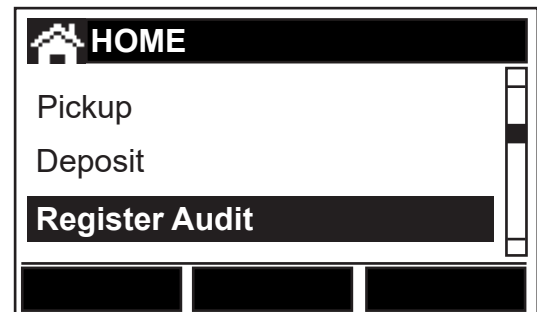
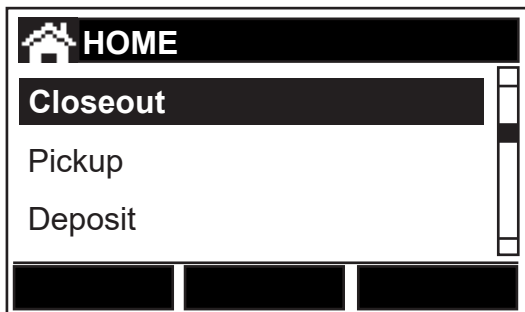

T-i^x multi-till has four different counting tasks which cover the requirements of a multi-till environment.

Closeout: Count an entire register and deduct standard bank. Adds to the GRAND TOTAL memory.

Pickup: Count skimmed Bills / Checks / Coupons and other non-cash items. Adds into register total in addition to the GRAND TOTAL.

Bank Preparation: Count cash ready for Banking. Banking totals are not added into the GRAND TOTAL.

Register audit: Perform a full register audit and deduct a standard bank, carry out a safe check or check a coin delivery. Register audit totals are not added into the GRAND TOTAL but simply treated

Counting - Multi Till



Tasks and Multiple Transactions

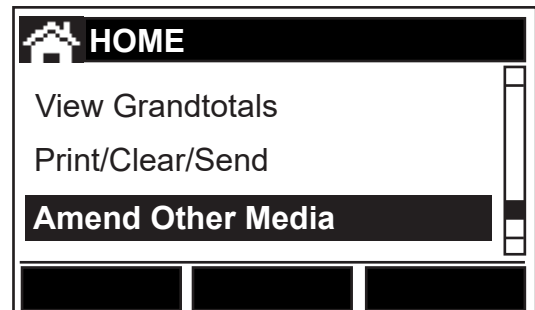
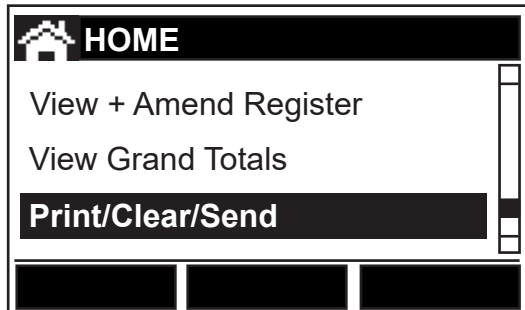



T-i^x multi-till has four additional tasks which assist the management of count information in a multi-till environment. These tasks can be accessed from the Home Page.



View & Amend Registers



VIEW & AMEND REGISTERS displays a list of drawer totals in addition to the current Grand Total for all registers counted. VIEW & AMEND REGISTERS also allows Amend, Print, Delete or Send data to a PC for individual registers.

Start at the Home Page. Using the  key, scroll to VIEW & AMEND REGS. Press .

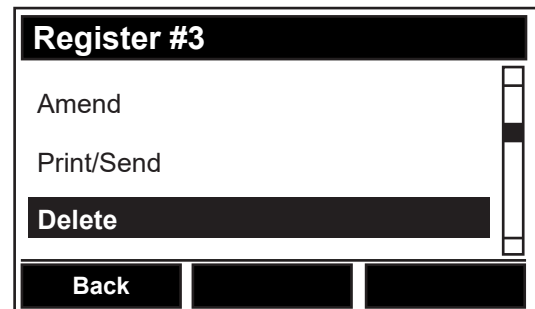
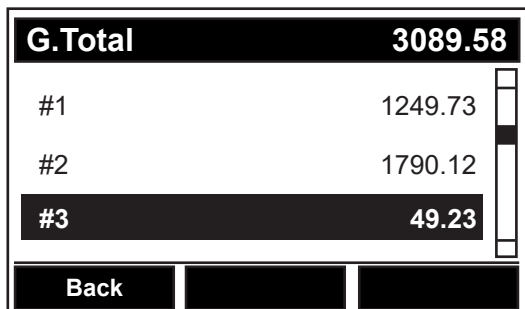
Using , scroll through the list of registers to highlight the required register and press . Four options are displayed: Amend, Print, Delete & Send (data to a PC). Use the  key to select the required option and press .







Amend Registers

Amend allows amendment of any reference numbers, bank values, cash, coupons, tokens or other media items by using the keypad to manually enter the change. If a mistake has been made that requires a re-count of a particular denomination, return to the counting task where the mistake was made (closeout or pickup) and re-enter the relevant drawer number. Using the  key, scroll to the relevant denomination. Press the  key to clear the value counted for that denomination and then re-count the money for that denomination only. All totals & grand totals affected by this amendment will be updated, and a print out will automatically be generated.

Counting - Multi Till

View Grand Totals

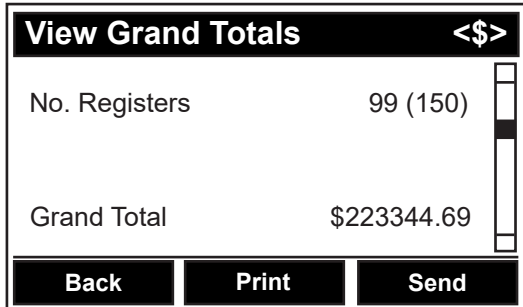

Displays the total number of registers counted and the combined grand total of all regs. Starting at the  page, use the  key to scroll to View Grandtotals and press . Data can be printed or sent with a full breakdown by denomination of the money counted across all registers by pressing the relevant  key.



If registers have been counted in more than one currency press the  key to view the other currencies.

Print/Clear/Send

Print

Start at the  page. Using the  key, scroll to Print/Clear/Send and press . The PRINT TOTALS screen will be displayed:

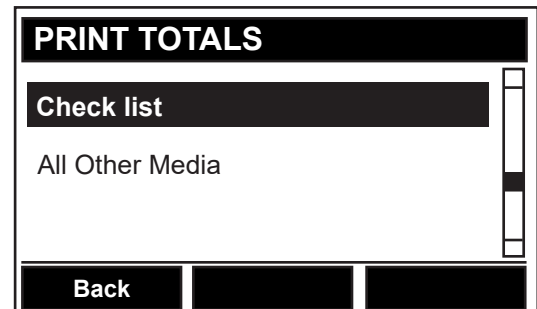
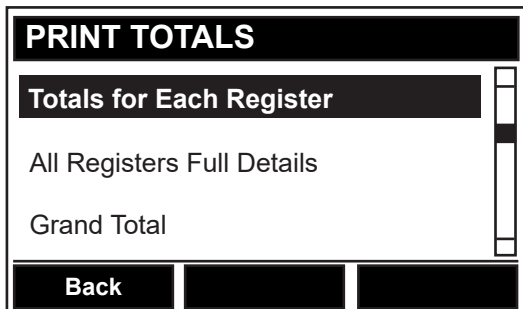

Here are descriptions of the print options available:*







- Totals for each register - Prints a summary of all register numbers and their individual totals.
- All Registers Full Details - Prints a full breakdown by denomination for each register counted.
- Grand Total - Prints a Grand Total summary by denomination.
- Check List - Prints a full listing of Checks entered for all registers.
- All Other Media - Prints a full listing of all media including Checks entered for all registers.

*Printer is an optional extra

Send Totals (PC)

To send totals to a PC use the  key to scroll to Send Totals (PC) and press . Data for all registers will be sent to the PC.

Clear all totals

To clear totals use the  key to scroll to CLEAR ALL TOTALS and press . The display will show "Clear all totals, are you sure?", use the  key, scroll to Yes press  to confirm.







IMPORTANT:

Totals must be cleared every day before beginning any counts for a new business day.



Settings



Settings

To access unit settings Start at the  page. Using the  key, scroll to SETTINGS and press .

Use the  key to select an option from the SETTINGS list and press  to enter that section. Each section is described individually in the following section of this user manual.

Date and Time



To set the date and time use the  key to highlight the area that needs to change and press the  key to scroll through permitted numbers. Hold down  for quick scroll.

Use the  key to move to highlight minutes and  to amend. Follow the same process to amend the date. Then press  to save changes.



For units that have a keypad follow above instructions but key in the numbers using the numeric keypad instead of using the navigation keys.

Language

To change the language, toggle between the two preset languages by using the right hand  key, labelled 'Change' then press .

Note: Only one language is permitted at a time.

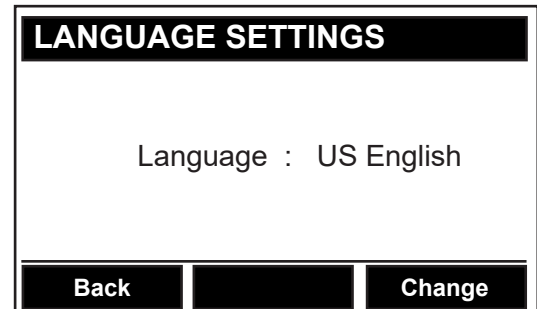

Sound

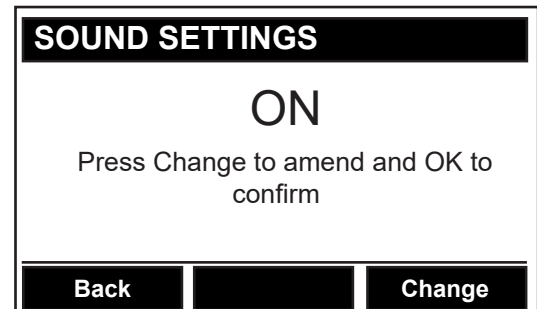

To Switch sound ON or OFF, follow on screen prompts.



Settings

Display Settings



Backlight

To switch the Backlight ON or OFF highlight "Backlight" in the "DISPLAY SETTINGS" screen by using the  key, then press .

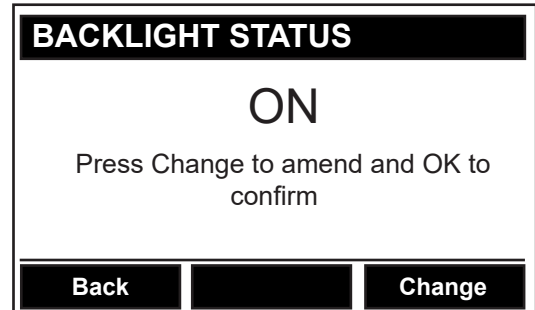
Then follow on screen instructions as seen in the illustration.





Contrast

To change the display contrast highlight contrast in the "DISPLAY SETTINGS" screen by using the  key, then press .

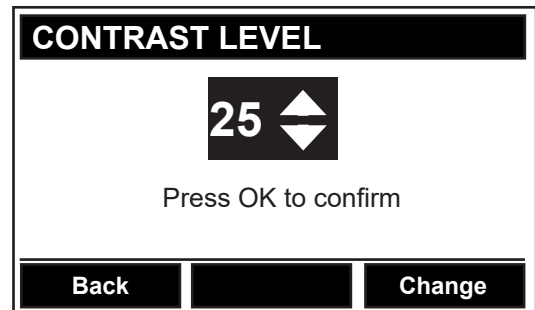
Then follow on screen instructions as seen in the illustration.



Port Settings

To enable/disable one of the available* ports select the port to be enabled / disabled using the  key then press the right hand  key to toggle between X and ✓. Press  to save changes.

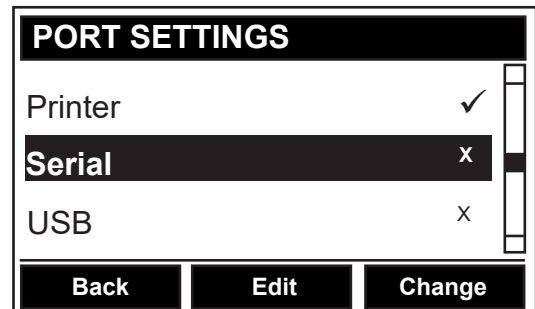

*Available ports will be different by model. Please see the table below





Model	USB A Port	Printer/Serial Port	USB B Port	Ethernet	Wi-Fi
1000	•				
2000	•	•			
3000	•	•	•		
3500	•	•	•		
3550	•	•	•		
4500	•	•	•	•	
4550	•	•	•	•	
5500	•	•	•		•

Set up Wizards

T-i^x set up wizards enable you to easily configure the unit to meet your needs.

From the  Page press the  key and highlight Setup Wizard. Now press .

T-i^x will now display the Set up Wizard screen (shown opposite*). Use the  key to highlight the item to be set up and press  to enter.



*Setup Wizard options will differ by model.







Please see table below to show what can be configured for each item using the relevant wizard:

Bill Wizard	Enable / disable and set weights for Bill denominations.
Coin Wizard	Enable / disable and set weights for Coin denominations.
Coupon Wizard	Enable / disable, edit name, set a value, set by number or value and set weights for each coupon.
Token Wizard	Enable / disable, edit name, set a value, set by number or value and set weights for each token.
Other Media Wizard	Enable / disable, & edit the name of each Key Entered Media item.
Reference Number Wizard	Enable / disable, & edit the name of each Reference Number.
Packaged Bill Wizard	Set package quantity and set weights and limits for packaged bills.
Packaged Coin Wizard	Set package quantity and set weights and limits for packaged Coins.
Currency Wizard	Enable / disable available currencies.
Count Task Wizard	Enable / disable and edit names of tasks.
Exchange Wizard	Enable / disable an exchange rate and to enter and exchange value.
Bank Wizard	Enable / disable and edit bank values.
Container Wizard	Enable / disable containers.

Diagnostics

From the  Page use the  key to highlight Diagnostics. Now press .

Use the  key to scroll through the menu items and press  to enter a selection. Alternatively, enter a selection using the  key then use the right hand  key to move through all diagnostics screens consecutively. To return a step, press the left hand  key.

Unit Information

Unit Information displays the time, date and software version of the unit. Press the middle  key to enter the 'set time and date' function, which is also accessible from the settings menu.

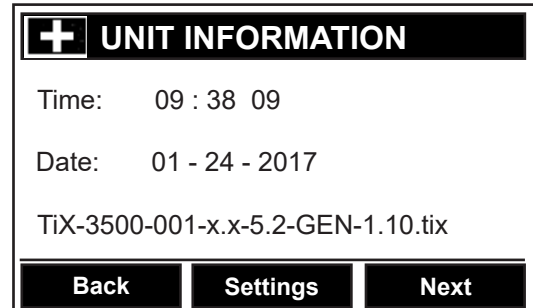

+ UNIT INFORMATION		
Time:	09 : 38 09	
Date:	01 - 24 - 2017	
TiX-3500-001-x.x-5.2-GEN-1.10.tix		
Back	Settings	Next

Noise check

This screen monitors the level of disturbance caused by drafts of air, vibrations and electronic interference, which could affect the performance of the unit. If the bar is full, cash counting conditions are optimal. If the bar is empty, conditions are poor and the unit should be placed in a more suitable location, away from any possible interference. If this does not solve the problem, the unit may need to be evaluated. Contact your supplier for assistance.

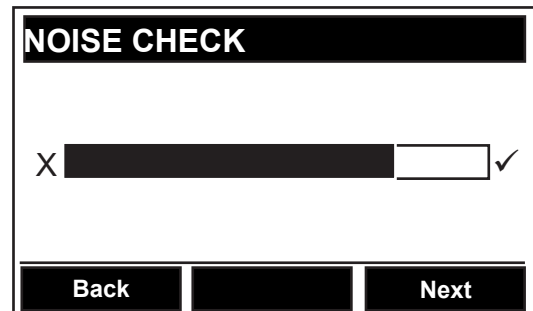

NOISE CHECK		
X		✓
Back		Next

Check Weight

A known weight can be checked here to 1 decimal place.

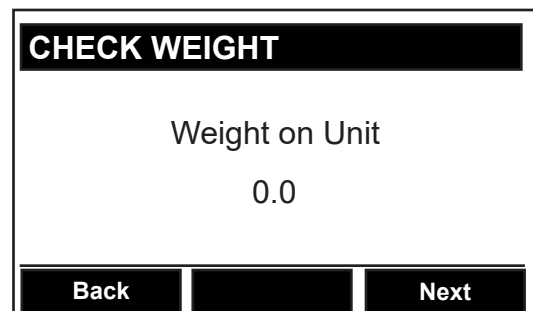



CHECK WEIGHT		
Weight on Unit		
0.0		
Back		Next

Bill/Band/Sleeve/Clip/Coin/Bag/Container weights

These sections are provided for the use of your helpline provider.

Weighing Scale

Weighing Scale

From the  Page use the  key to highlight Weighing Scale. Now press .

The following screen will be displayed:

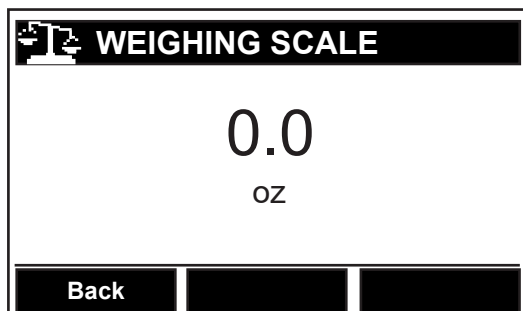

The maximum working capacity of T-i^x is 4lb 6oz.

Bill: The weighing scale function is not an 'Approved legal for trade' function.

Technical Specification

EC Declaration of Conformity

This is to certify that the Tellermate money counter

T-i^x Series

Manufactured by Tellermate Ltd, Leeway, Newport, NP19 4SL, UK, conforms to the following EC Directives:

Low Voltage Directive 2014/55/EU

Electromagnetic Compatibility (EMC) Directive 2014/30/EU

Restriction of Hazardous Substances (RoHS) Directive 2011/65/EU



Complies with EU Directive 2002/95/EC on the restriction of use of certain hazardous substances in electrical & electronic equipment.

Complies with the Waste Electrical & Electronic Equipment Directive 2002/96/EC. Consult your supplier before disposal.

Signed for Tellermate Limited

M. Bernhardt
Group Products Director

Technical Specification

Load capability:

Maximum load - 4lbs 6oz (2kg)
Counting resolution - 1 banknote/coin

Dimensions:

T-i^x including Money Platform
Length 11.4" (291 mm)
Width 6.0" (152 mm)
Height 6.5" (166 mm)

Weight:

T-i^x - 2lbs 2oz (0.98 kg)
Battery - 1.7oz (0.049 kg)

Power supply:

Power adapter
Input to suit country of use.
Output 5V AC 1.2A

Power connection

6.5 mm reverse jack on the rear panel.

Power indication

Green LED on the lower front face illuminates on power from the power supply or PC USB connection.

Battery:

Removable, rechargeable Li-ion
Duration: Over 12 hours constant use.
Charging time: 4 hours using the power supply provided.

External interfaces:

USB - A

For upgrading product software

Serial (optional)

For connection to a Tellermate supplied printer

USB - B (optional)

For connection to PC for data transfer

Ethernet (optional)

Ethernet Adaptor FCC68 cat 5, 8-way connector to network

Display:

Full Graphic LCD
3.0" x 1.6" (77 mm x 41 mm)
240 x 128 pixel resolution
Adjustable backlight and contrast

Soft touch keys:

3 'soft key' fast access keys
Navigation D pad and confirmation
On/Off, Home, Clear Entry, End Count

Environmental requirements:

Temperatures

Storage: -4°F to 140°F (-20°C to 60°C)
Operating: 40°F to 104°F (5°C to 40°C)

Humidity

All times: 0-95% RH non-condensing



3600 Mansell Road
Suite 500
Alpharetta, GA 30022
USA

Alternative Contact Details:

If you have purchased this unit from a Tellermate
Partner, they may have put alternative contact details
here: